



Call 1800 103 2468 / 1860 500 2468 or  
visit [www.aosmithindia.com](http://www.aosmithindia.com)



Plot No. 300, Phase - II, KIADB Industrial Area, Harohalli, Kanakapura Taluk,  
Ramanagara District, Karnataka – 562 112, India. CIN: U31909KA2006PTC040282  
[www.aosmithindia.com](http://www.aosmithindia.com) | <https://www.facebook.com/aosmithin> | <https://twitter.com/AOSmithin>

AOS/NWH\_R1/03/21



**World's No.1**  
MANUFACTURER OF WATER HEATERS







## SAY HELLO TO A. O. SMITH.

Founded in 1874 by Charles Jeremiah Smith, the A. O. Smith Corporation began as an engineering company in Milwaukee, Wisconsin. Today, we are the global leaders in making water heaters. This drives our pursuit for excellence when it comes to water purifiers as well. For the past 147 years, our singular purpose has been to create stellar products that deliver the best performance with the best technology. And to this day, we live strongly by that belief.

## OVER A CENTURY OF INNOVATION.

A. O. Smith enjoys a rich history of achievements. A glimpse at our 147-year history reveals numerous engineering and technical achievements.



**1874**

Started operations



**1936-1954**

Patented the glass line technology and introduced the first glass-lined commercial water heater



**2008**

Started operations in India



**2015**

Entry in Water Purification-Pioneers in introducing the Hot Water feature

**1889-1906**

Foray's into the bicycle industry and over the years became North America's largest automobile frame manufacturer



**1995**

Joint venture in China



**2010**

Factory set up in Harohalli, Bengaluru 2010 - Water Heater Manufacturing begins



**2019-2020**

Launched a new range of residential Water Heaters in India





# The Blue Diamond® Story.

A. O. Smith was credited with the invention of the glass-lined water heater tanks in 1936. After this, the next breakthrough was the Blue Diamond® technology in 2004. In this technology, a specially formulated glass frit is bonded to the steel through a complex process that is carried out at over 800°C. The Blue Diamond® Glass-Lining technology reduces scaling accumulation on the tank caused by minerals, corrosion due to hard water and leakage of heat into the atmosphere. It also enhances the strength and durability of the tank.

All A. O. Smith water heaters come with Blue Diamond® Glass-Lining technology, replacing the earlier stainless steel water heaters that were prone to rusting, corrosion and scaling due to the contact between hot water and steel.

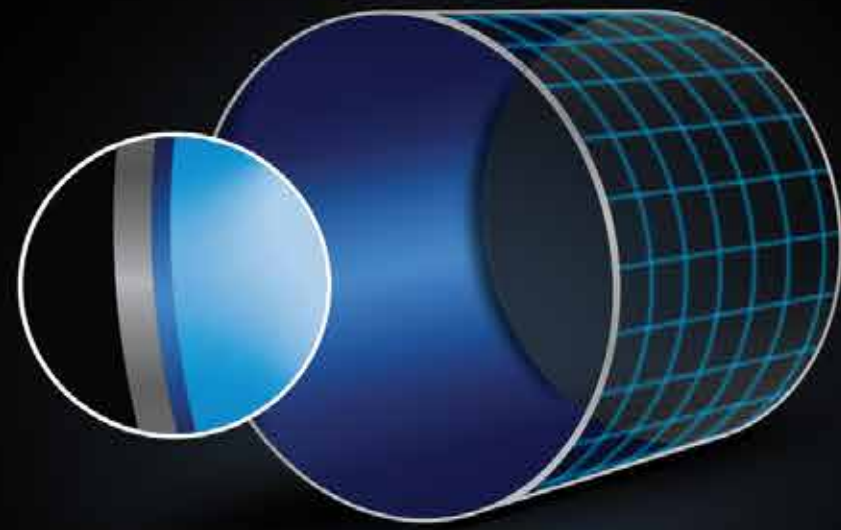

This **Blue Diamond® technology** provides twice the corrosion resistance compared to industry standards and increases the life span of the tank.

# Setting Benchmarks.

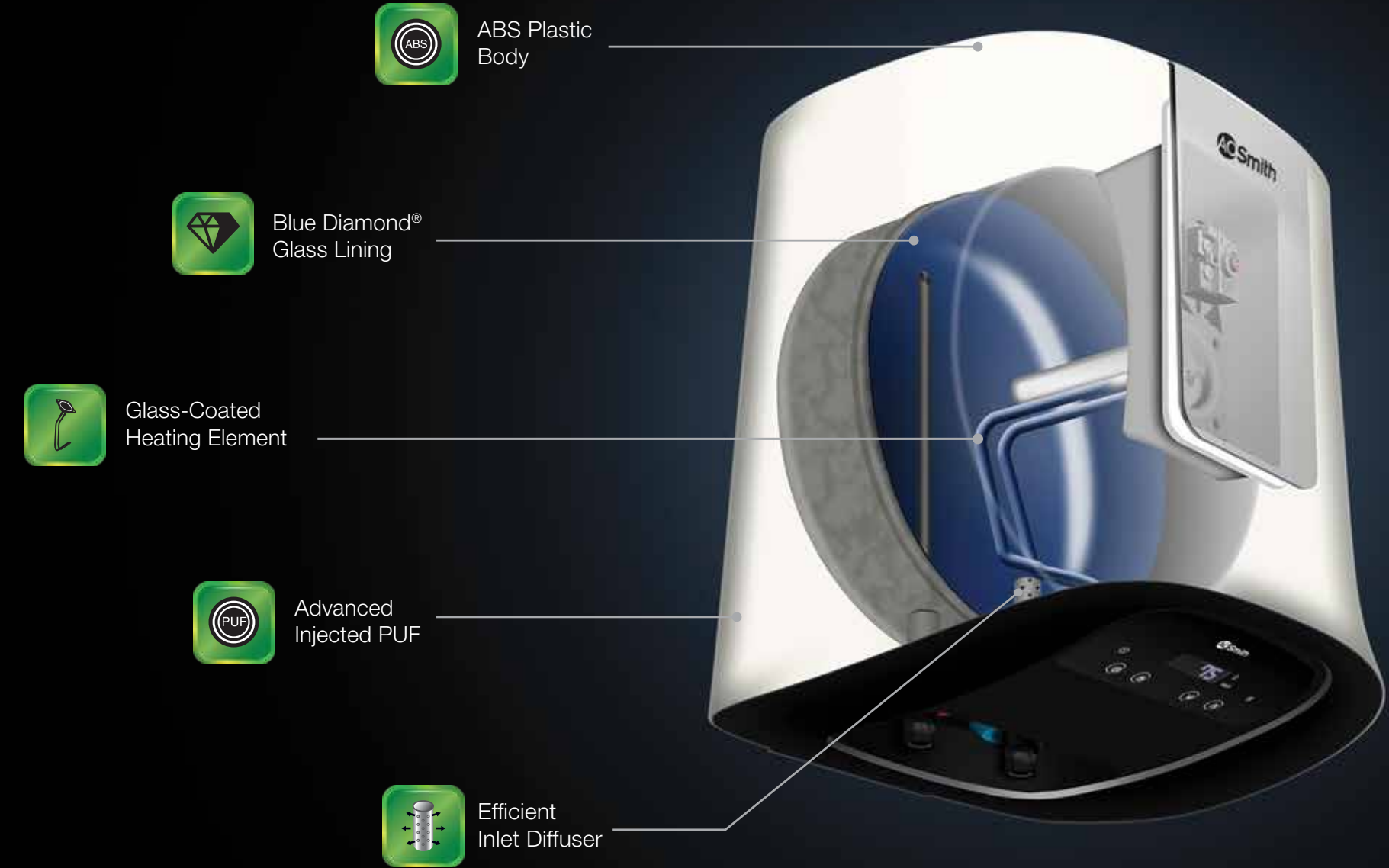

HeatBot®

## UPGRADE TO THE ART OF SMART BATHING







Redefine your bathing experience with the new Heatbot that rejuvenates and relaxes your senses. Elevate your bath and bathroom with this pure art, backed by **intelligent design and functionality.**







HeatBot®  
15/25 (L)

## FUTURE-READY

-  Easy Operation with Wireless Remote
-  Hot Water Ready at anytime with Smart Timer Mode
-  Track your Energy Use with Energy Meter
-  Sleek & Modern Masterpiece to Elevate your Bathroom

## WORRY-FREE

-  Blue Diamond® Glass-Lined Tank for 2X corrosion resistance.
-  Long-lasting Anode Rod with 2X lifespan even in hard water conditions.

-  7-year warranty on tank. 2+2 year warranty on Glass Coated Heating Element.
-  Double Protection with Thermal Cut-Out and Multi-function Safety Valve.

## ECO-FRIENDLY

-  BEE 5-star rated with Advanced PUF Technology for Power Savings. Perfect if you want to go green.

## EASY-TO-USE

-  Convenient Display & Intuitive Controls





# HeatBot®



## Digital Model : SZS-DG

- Capacity :** 15L, 25L
- Product Color :** White | Silver
- Power(KW) :** 2
- Rated Water Pressure:** 8 Bars



## Mechanical Model : SZS

- Capacity :** 15L, 25L
- Product Color :** White | Silver
- Power(KW) :** 2
- Rated Water Pressure:** 8 Bars

## Storage Water Heater

### Product Dimensions

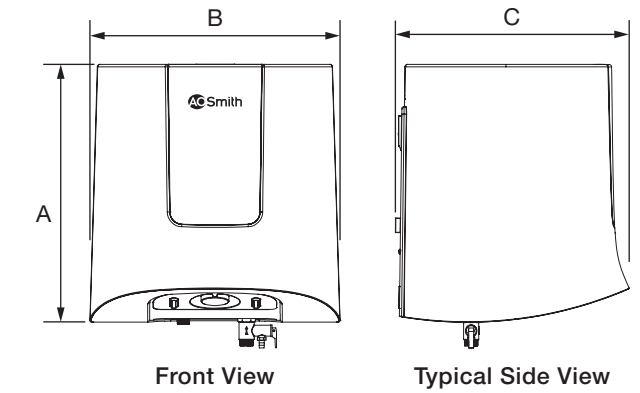

All Dimensions in mm

Model Name	A	B	C
SZS-DG-015   SZS-015	408	395	328
SZS-DG-025   SZS-025	486	444	400

Note: A. O. Smith reserves the right to amend or modify the specifications and features at any time, as and when required without any prior notification.



## TIME IS A LUXURY - XPRESS SERIES UNDERSTANDS IT

Our Xpress series values your time. This is why they give you hot water 33% faster compared to ordinary water heaters of 2KW. Adept with Smart modes to provide water as per application requirement, you'll be surprised at the amount of time these water heaters can save for you.

# xpress



**Capacity :** 6L, 10L, 15L, 25L  
**Product Color :** White  
**Power (KW) :** 3  
**Rated Water Pressure :** 8 Bars



**Smart Modes** enable you to customise your hot water requirements as you like it



**Express Heat** with 33% faster heating than 2 kw water heaters.



**Longer life** in toughest water conditions with Blue Diamond® glass lined tank



**Long lasting** performance with glass coated incoloy heating element



**Double Protection** of your family with Thermal Cut-out and Safety Valve.



**Long-lasting Anode Rod** 2X lifespan as compared to normal magnesium rod.

Experience  
**SMART MODES**



SHOWER



BUCKET



PEDICURE



WASHING



MOPPING

## Storage Water Heater

### Product Dimensions

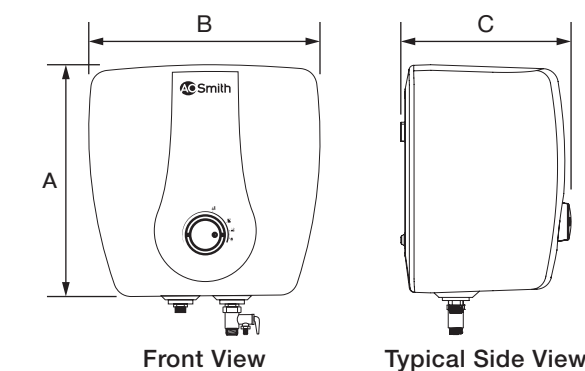

All Dimensions in mm

Model Name	A	B	C
XPRESS-006	317	317	258
<b>XPRESS-010</b>	373	373	277
XPRESS-015	373	373	348
<b>XPRESS-025</b>	444	444	383

Note: A. O. Smith reserves the right to amend or modify the specifications and features at any time, as and when required without any prior notification.



Inner Tank	Glass Coated Heating Element	Product
7 years	4 years	2 years

Colours shown are only indicative and may vary from actual colours available.





## AESTHETICS AND PERFORMANCE REDEFINED

Finesse series equipped with Smart Modes facilitates hot water as per your requirement. With its best-in-class design, Blue Diamond Glass lining coupled with maximum energy efficiency, FINESSE range of water heaters are built to last a lifetime and provide you a seamless bathing experience.

# finesse



**Capacity :** 6L, 10L, 15L, 25L  
**Product Color :** White  
**Power (KW) :** 2  
**Rated Water Pressure :** 8 Bars



**Smart Modes** enable you to customise your hot water requirements as you like it



**Maximum energy savings** with BEE 5 Star rating



**Longer life** in toughest water conditions with Blue Diamond® glass lined tank



**Long lasting** performance with glass coated incoloy heating element



**Double Protection** of your family with Thermal Cut-out and Safety Valve.



**Long-lasting Anode Rod** 2X lifespan as compared to normal magnesium rod.

Experience  
**SMART MODES**



SHOWER



BUCKET



PEDICURE



WASHING



MOPPING

## Storage Water Heater

### Product Dimensions

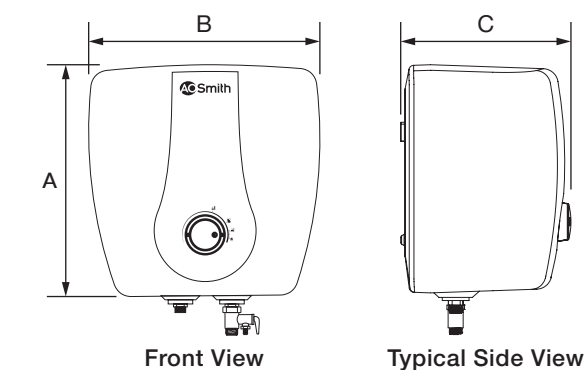

All Dimensions in mm

Model Name	A	B	C
FINESSE-006	317	317	258
<b>FINESSE-010</b>	373	373	277
FINESSE-015	373	373	348
<b>FINESSE-025</b>	444	444	383

Note: A. O. Smith reserves the right to amend or modify the specifications and features at any time, as and when required without any prior notification.



Inner Tank	Glass Coated Heating Element	Product
7 years	4 years	2 years

Colours shown are only indicative and may vary from actual colours available.





## EFFICIENT AND DURABLE

With Blue Diamond® Glass lined tank, the Urbane series is designed to perform the best, even in toughest of water conditions.

# Urbane



**Capacity :** 6L, 10L, 15L, 25L

**Product Color :** White

**Power (KW) :** 2

**Rated Water Pressure :** 8 Bars



**Longer life** in toughest water conditions with Blue Diamond® glass lined tank



**Maximum energy savings** with BEE 5 Star rating



**Long lasting** performance with glass coated incoloy heating element



**Double Protection** of your family with Thermal Cut-out and Safety Valve.



**Long-lasting Anode Rod**  
2X lifespan as compared to normal magnesium rod



Inner Tank	Glass Coated Heating Element	Product
7 years	4 years	2 years

## Storage Water Heater

### Product Dimensions

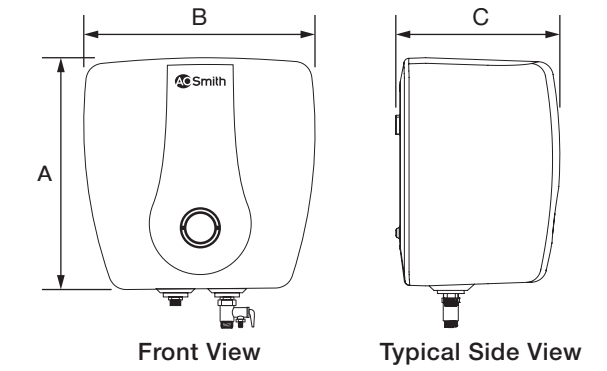

All Dimensions in mm

Model Name	A	B	C
URBANE-006	317	317	249
URBANE-010	373	373	269
URBANE-015	373	373	338
URBANE-025	444	444	373

Note: A. O. Smith reserves the right to amend or modify the specifications and features at any time, as and when required without any prior notification.

Colours shown are only indicative and may vary from actual colours available.



SUITABLE FOR  
**LOFT  
MOUNTING**

## COMPACT WATER HEATER WITH STATE-OF-ART TECHNOLOGY

With its sleek design and horizontal orientation, ELEGANCE-SLIM are designed to fit into tight spaces. Available in RHS and LHS variants to facilitate hassle free installation.

elegance  
*Slim*



<b>Capacity :</b> 15L, 25L
<b>Product Color :</b> White
<b>Power (KW) :</b> 2
<b>Rated Water Pressure :</b> 8 Bars
<b>BEE Star Rating :</b> 3 Stars



**Compact size** ergonomically and aesthetically designed water heater



**Longer life** in toughest water conditions with Blue Diamond® glass lined tank



**Long lasting** performance with glass coated incoloy heating element



**Double Protection** of your family with Thermal Cut-out and Safety Valve.



**Long-lasting Anode Rod**  
2X lifespan as compared to normal magnesium rod.



**Easy access** temperature control knob for choice of bathing water 25°C - 75°C



Inner Tank	Extended Warranty* on Heating Element	Product
7 years	2+2 years	2 years

### Product Dimensions

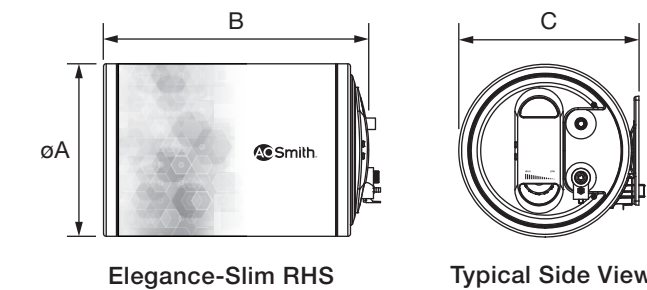

All Dimensions in mm

Model Name	A	B	C
ELEGANCE-SLIM-015	320	492	334
ELEGANCE-SLIM-025	320	694	334

Note: A. O. Smith reserves the right to amend or modify the specifications and features at any time, as and when required without any prior notification.

Elegance Slim models are available in both with right-hand side and left-hand side inlet outlet configuration.





## ENERGY SAVING WATER HEATER WITH BEAUTIFUL AESTHETICS

Elegance water heaters feature BEE 4 star rating and saves on energy costs. With its compact size, it can easily fit in lofts and above false ceilings of your bathroom.

## elegance



<b>Capacity :</b> 15L, 25L
<b>Product Color :</b> White
<b>Power (KW) :</b> 2
<b>Rated Water Pressure :</b> 8 Bars
<b>BEE Star Rating :</b> 4 Stars



**Compact size** ergonomically and aesthetically designed water heater



**High energy efficiency** with BEE 4 Star rating



**Longer life** in toughest water conditions with Blue Diamond® glass lined tank



**Long lasting** performance with glass coated incoloy heating element



**Double Protection** of your family with Thermal Cut-out and Safety Valve.



**Long-lasting Anode Rod** 2X lifespan as compared to normal magnesium rod.



Inner Tank	Extended Warranty* on Heating Element	Product
7 years	2+2 years	2 years

## Storage Water Heater

### Product Dimensions

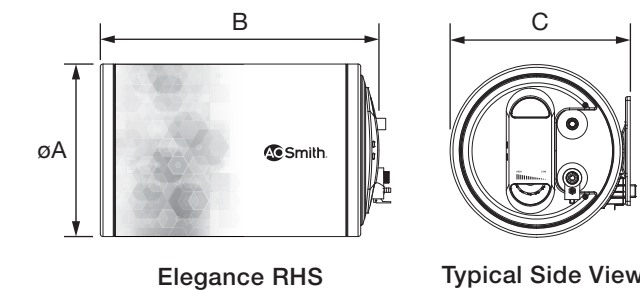

All Dimensions in mm

Model Name	A	B	C
ELEGANCE-015	338	509	352
ELEGANCE-025	338	704	352

Note: A. O. Smith reserves the right to amend or modify the specifications and features at any time, as and when required without any prior notification.

Elegance models are available in both with right-hand side and left-hand side inlet outlet configuration.

Colours shown are only indicative and may vary from actual colours available.



## BIG ON PERFORMANCE

With its Blue Diamond Glass lining & Glass coated Incoloy Heating element, HAS-X models available in 35 & 50 litre variants are built for a long lasting performance. Available in RHS and LHS i/o piping variants for a hassle free installation.

## HAS-X



<b>Capacity :</b> 35L, 50L
<b>Product Color :</b> White
<b>Power (KW) :</b> 2
<b>Rated Water Pressure :</b> 8 Bars
<b>BEE Star Rating :</b> 4 Stars



**Longer life** in toughest water conditions with Blue Diamond® glass lined tank



**Long lasting** performance with glass coated incoloy heating element



**Long-lasting Anode Rod**  
2X lifespan as compared to normal magnesium rod.



**Temperature Control Knob**  
Easy temperature settings.



**Advanced PUF Insulation**  
High energy efficiency and power savings.



Inner Tank	Extended Warranty* on Heating Element	Comprehensive
7 years	2+2 years	2 years

## Storage Water Heater

### Product Dimensions

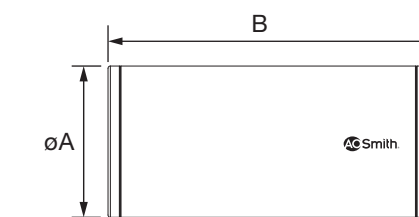

Front View

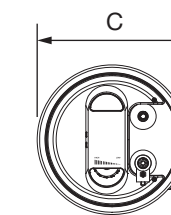

Typical Side View

All Dimensions in mm

Model Name	A	B	C
HAS-X-035	395	659	408
HAS-X-050	395	875	408

Note: A. O. Smith reserves the right to amend or modify the specifications and features at any time, as and when required without any prior notification.

HAS-X models are available in both with right-hand side and left-hand side inlet outlet configuration.

Colours shown are only indicative and may vary from actual colours available.











## BUILT FOR HIGH CAPACITY

With Glass coated Incoloy heating element, Blue Diamond Glass lined tanks coupled with a sturdy outer body ensures superior performance, extended durability and large capacity designed for years to come.

## HSE-HAS



<b>Capacity :</b> 70L, 100L
<b>Product Color :</b> White
<b>Power (KW) :</b> 3
<b>Rated Water Pressure :</b> 8 Bars
<b>BEE Star Rating :</b> 4, 2 Stars

-  **Longer life** in toughest water conditions with Blue Diamond® glass lined tank
-  **Temperature Control Knob**  
Easy temperature settings.
-  **Long lasting** performance with glass coated incoloy heating element
-  **Advanced PUF Insulation**  
High energy efficiency and power savings.
-  **Long-lasting Anode Rod**  
2X lifespan as compared to normal magnesium rod.
-  **Ease of plumbing** with bottom inlet outlet connection

	Inner Tank	Extended Warranty* on Heating Element	Comprehensive
	7 years	2+2 years	2 years

## Storage Water Heater

### Product Dimensions

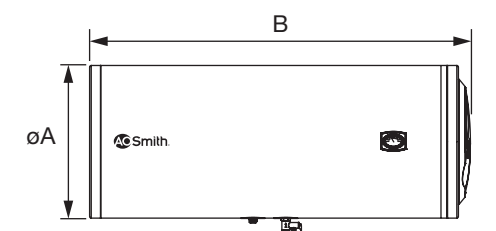

Front view

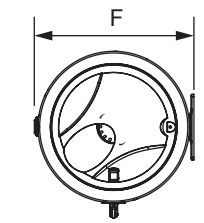

Right view

All Dimensions in mm

Model Name	A	B	C
HSE-HAS-070	465	900	490
HSE-HAS-100	465	1155	490

Note: A. O. Smith reserves the right to amend or modify the specifications and features at any time, as and when required without any prior notification.

Colours shown are only indicative and may vary from actual colours available.



## A DESIGN MARVEL

Sturdy tank construction with rust proof outer body ensures a lifetime performance. Saves on energy bills with 5 Star rating and it's sleek design also elevates your bathroom décor.

# elegance



<b>Capacity :</b> 15L, 25L
<b>Product Color :</b> White
<b>Power (KW) :</b> 2
<b>Rated Water Pressure :</b> 8 Bars
<b>BEE Star Rating :</b> 5 Stars



**Compact size** ergonomically and aesthetically designed water heater



**Longer life** in toughest water conditions with Blue Diamond® glass lined tank



**High energy efficiency** with BEE 5 Star rating



**Long lasting** performance with glass coated incoloy heating element



**Double Protection** of your family with Thermal Cut-out and Safety Valve.



**Long-lasting Anode Rod** 2X lifespan as compared to normal magnesium rod.



Inner Tank	Extended Warranty* on Heating Element	Comprehensive
7 years	2+1* years	2 years

## Storage Water Heater

### Product Dimensions

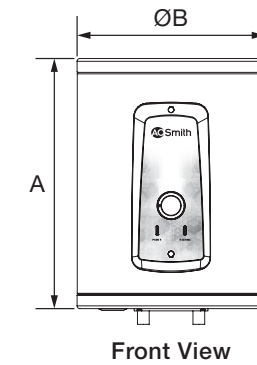

Front View

All Dimensions in mm

Model Name	A	ØB
ELEGANCE-015	440	Ø338
ELEGANCE-025	644	Ø338

Note: A. O. Smith reserves the right to amend or modify the specifications and features at any time, as and when required without any prior notification.

Colours shown are only indicative and may vary from actual colours available.





## MiniBot® | Instant Water Heater

# Why settle for ordinary?

The **MiniBot® instant water heater** is a masterpiece with an outstanding design and cutting edge technology, redefining the instant water heater category. You may say it's a perfect balance of form and function that will make your bathroom look magnificent and extraordinary. That's why we say... **Why Settle For Ordinary?**



## MINIBOT®



- Capacity : 3L
- Product Color : White | Black
- Power (KW) : 3 | 4.5
- Rated Water Pressure : 8 Bars



**Beautifies your bathroom** with modern minimalistic design



**Get instant hot water** with glass coated heating element



**Longer life** in toughest water conditions with Blue Diamond® glass lined tank



**Designed for high rise buildings** with 8 bar pressure rating



**Stronger construction quality** with tank thickness of 2 mm, **2X compared** to an ordinary instant water heater



Inner Tank	Extended Warranty* on Heating Element	Comprehensive
5 years	2+1 years	2 years

## Instant Water Heater

### Product Dimensions

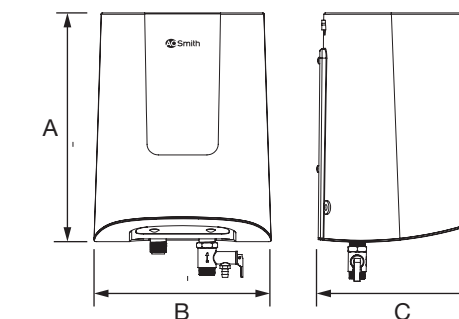

All Dimensions in mm

Model Name	A	B	C
MiniBot®	317	236	228

Note: A. O. Smith reserves the right to amend or modify the specifications and features at any time, as and when required without any prior notification.

Colours shown are only indicative and may vary from actual colours available.

# FAST-ON<sup>®</sup>

Instant Water Heater



**MOST  
COMPACT**  
Instant Water Heater\*

\*As compared with all leading national brands of water heaters in terms of height in 3 Litres tank capacity.



## FAST-ON<sup>®</sup>



Capacity : 3L
Product Color : White   Black
Power (KW) : 3   4.5
Rated Water Pressure : 8 Bars



**Easily fits** into your bathroom or kitchen with its Super Compact Size, minimalistic design and beautiful aesthetics



**Get instant hot water** with high powered heating element



**Longer life** in toughest water conditions with Blue Diamond<sup>®</sup> glass lined tank



**Designed for high rise buildings** with 8 bar pressure rating



**Stronger construction quality** with tank thickness of 2 mm, **2X compared** to an ordinary instant water heater



Inner Tank	Heating Element	Comprehensive
5 years	2 years	2 years

## Instant Water Heater

### Product Dimensions

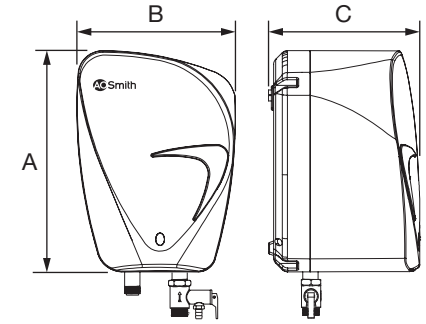

All Dimensions in mm

Model Name	A	B	C
FAST-ON <sup>®</sup>	306	219	209

Note: A. O. Smith reserves the right to amend or modify the specifications and features at any time, as and when required without any prior notification.

Colours shown are only indicative and may vary from actual colours available.



# STYLISH OUTSIDE. INNOVATION AND TECHNOLOGY INSIDE.

Our water heaters aren't just impressive on the outside. They're equally world-class on the inside. That's why you get a 7-year warranty\* on the tank, a 4-year extended warranty\* on the heating element and a 2-year comprehensive product warranty\* that promises safety and longevity.



## Ti Steel Tanks

A. O. Smith water heaters now come with a specially designed Titanium steel tank that ensures sturdy construction, longer life and superior quality that is unmatched. The Titanium steel combined with our patented Blue Diamond® coating is the most technologically advanced combination & gives A. O. Smith water heaters resistance to corrosion even in hard waters.



## Advanced PUF Technology

The advanced PUF injection ensures uniform and high density foam distribution. Complete coverage of the PUF in between the tank & outer jacket greatly reduces the heat loss. This ensures maximum energy efficiency and power savings.



## Smart Modes

Smart Modes enable you to customise your hot water requirements as you like it.



## Fold Back Heating Element

Fits the shape of the tank, ensuring uniform heating and continuous and maximum availability of hot water.

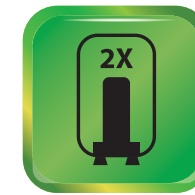

## Long-Lasting Anode Rod

A customised alloy that works even in hard water conditions to protect the tank and has 2X lifespan as compared to a magnesium alloy commonly used in most water heaters.



## Thermostat

Helps in setting the temperature of your water for a relaxing bath.



## Thermal Cut-Out for Safety

If the water temperature exceeds the highest preset limit then this automatically cuts off the power supply to the water heater for your family's safety.

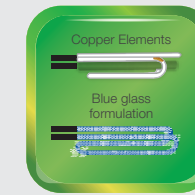

## Glass-Coated Heating Element\*

Incoloy heating element protected by glass coating to prevent scale formation and extend the life of heating element.



## Wire Harness and Power Cord

Complying to the stringent standards of UL 1015 for wires, IS 694 for cables and IS 1293 for plug.

\*Features may vary as per model

PRODUCTS	MECHANICAL									INSTANT	
	SZS	XPRESS	FINESSE	URBANE	ELEGANCE-SLIM	ELEGANCE	HAS-X	HSE-HAS	ELEGANCE	FAST-ON	MINIBOT
											
<b>CONVINEINCE</b> Blue Diamond® glass lining	✓	✓	✓	✓	✓	✓	✓	✓	✓	✓	✓
Glass coated heating element	✓	✓	✓	✓	✓	✓	✓	✓	✓	✓	✓
Smart Mode	-	✓	✓	-	-	-	-	-	-	-	-
LED Indicators	✓	✓	✓	✓	✓	✓	✓	✓	✓	✓	✓
Temperature control knob	✓	✓	✓	-	✓	✓	✓	✓	✓	-	-
Express Heat	-	✓	-	-	-	-	-	-	-	✓	✓
Thermal cut-out	✓	✓	✓	✓	✓	✓	✓	✓	✓	✓	✓
Anode rod	✓	✓	✓	✓	✓	✓	✓	✓	✓	✓	✓
Safety valve	✓	✓	✓	✓	✓	✓	✓	✓	✓	✓	✓
Adjustable Thermostat	✓	✓	✓	✓	✓	✓	✓	✓	✓	-	-
Capacity	15   25	06   10   15   25	06   10   15   25	06   10   15   25	15   25	15   25	35   50	70   100	15   25	3	3
Power[W]	2000	3000	2000	2000	2000	2000	2000	3000	2000	3000   4500	3000   4500
Mounting	Wall	Wall	Wall	Wall	Wall & Loft	Wall & Loft	Wall	Wall	Wall	Wall	Wall

PRODUCTS	DIGITAL
	SZS-DG
	
<b>DIGITAL</b> Blue Diamond® glass lining	✓
Glass coated heating element	✓
Digital Display	✓
Remote	Wireless
Energy Meter	✓
Digital Clock	✓
Digital Temperature Setting	✓
Smart Timer Mode (Auto on/off)	✓
Thermal cut-out	✓
Anode rod	✓
Safety valve	✓
Adjustable Thermostat	✓
Capacity	15   25
Power[W]	2000
Mounting	Wall

## HOW TO CHOOSE YOUR WATER HEATER.

Capacity is the primary criteria which depends on the kind of usage.

**Kitchen**

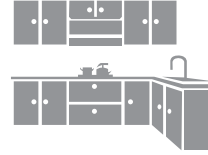

Suggested Capacity in Litres 3 / 6

**Bucket**



Suggested Capacity in Litres 10 / 15

**Normal shower**



Suggested Capacity in Litres 25

**Body shower panel**

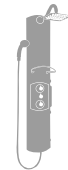

Suggested Capacity in Litres 35 / 50

**Rain shower**

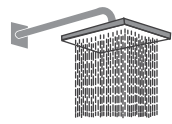

Suggested Capacity in Litres 50 / 70

**Bath tub**



Suggested Capacity in Litres 100 / 200

**Jacuzzi**



Suggested Capacity in Litres Above 200

# DISCLAIMER

1. Product images / color shown may vary from actual model. Design, feature and specifications mentioned are subject to change without notice. Applicable for all models.
2. Anode: A. O. Smith customized anode has a minimum of 2X more life when compared to a regular magnesium anode of similar dimensions, when tested under standard lab test conditions.
3. Blue diamond: A. O. Smith Smith Blue Diamond® glass lining has a minimum of 2X more durability when compared to a regular glass coating, when exposed to hot water in standard lab test conditions.



# WARRANTY

## Product Warranty

Your A. O. Smith Water Heater is warranted against defects arising from faulty design, workmanship and materials for a period of 24 months from the date of the invoice, subject to the following conditions:

1. The customer will notify the Company promptly about defects noticed and give the Company or its Authorised Service Provider adequate opportunity to inspect, test and remedy them, for which the customer will deposit the goods, if necessary, with the Company's Office/Authorised Service Provider along with the original invoice.
2. Special warranty from the date of purchase is only applicable for the below mentioned components:

Tank	7 Years
Glass-Coated Heating Element	4 Years
Product Warranty	2 Years

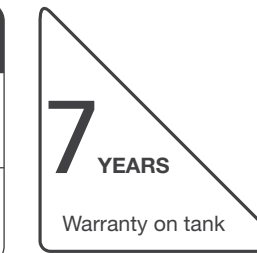

Applicable for XPRESS, FINESSE Models.

Tank	7 Years
Glass-Coated Heating Element	3 Years
Product Warranty	2 Years



Applicable for URBANE Model.

Tank	7 Years
Glass-Coated Heating Element	2 + 2 Years
Product Warranty	2 Years

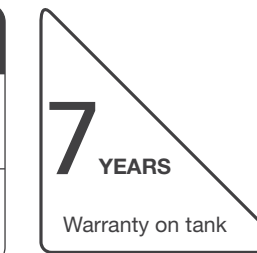

Applicable for, SZS, SZS-DG, ELEGANCE-SLIM & ELEGANCE, HSE-HAS-X, Models.

Tank	5 Years
Glass-Coated Heating Element	2 + 1 Years* 2 Years#
Product Warranty	2 Years



(a) Applicable for MINIBOT\*, (b) Applicable 2 Years# Warranty on Heating Element on FASTON Models.

\*Extended Warranty: Registration of Extended Warranty is valid if customer registers the product within 60 days of purchase. For more details log on to [www.aosmithindia.com](http://www.aosmithindia.com)





# proplanet

## Series

In addition to water heaters, we've also brought international standard water purifiers to India. Our range of water purifiers offer everything you've thought of, and more. Engineered with the finest technologies, our water purifiers are intuitive, efficient and beautiful. Whether it's top of the line, 5 star rated\* A.O. Smith ProPlanet series, Green series, the invisible under the counter models Z2+ and X5+ or the UV models Z1 and X2, find one that best suits your needs.



Ordinary RO water purifiers use four glasses of water to make just one glass of clean water. But A. O. Smith water purifiers with Advance Recovery Technology™ (ART™) save 2X more water\*. With high water recovery of 60% in ProPlanet series, you save more than 9000L of water annually\*, which is potentially enough for 2 families of 4. Unlike ordinary RO purifiers, the water doesn't bypass the RO membrane. Instead, we pass 100% of the water through it. What this means is that all the water is purified with minimal wastage.